

**INSTRUCTION MANUAL**

# FunScope

**Newtonian Reflector**

**#10033**



IN 374 Rev. C 03/15

*Congratulations on your purchase of a FunScope telescope.* Your new FunScope is easy to use and arrives from the factory almost fully assembled! Only the finder and eyepieces need to be installed. These instructions will help you set up and use your FunScope telescope, please read them thoroughly.

The FunScope will provide years of enjoyment of many night-sky treasures including breathtaking views of the Moon, planets, and even some bright deep sky objects.

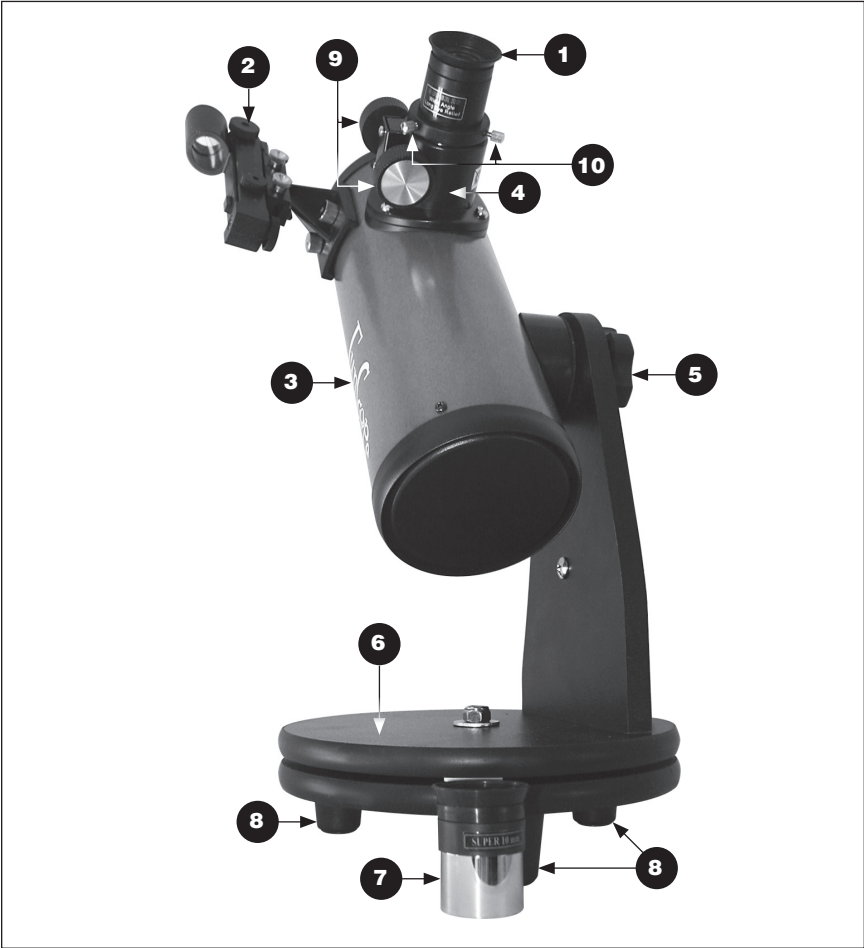

**Figure 1:** Overview of the FunScope

---

## FunScope Parts (refer to Figure 1)

- 1 20mm eyepiece:** The eyepiece is the part of the telescope that you actually look through to see things. The focal length of the eyepiece and the telescope determines the magnifying power. Magnification is discussed in more detail in the **Using Your Telescope** section
- 2 Red-dot finder reflex sight:** This is a special “finder” that helps you aim the telescope and locate objects in the sky for viewing. The Red-dot finder generates a red LED “dot” that shows where your telescope is aimed. The use of the Red-dot finder is discussed in the **Getting Started** section.
- 3 Optical tube:**  
This is the main component of the telescope.
- 4 Focuser:** This is where the eyepiece is inserted, and how sharpness is adjusted. Details of the focuser are shown in Figure 2.
- 5 Altitude tension adjustment knob:** By tightening and loosening this knob, you can change the amount tension in the altitude (up/down) motion of the telescope.
- 6 Altazimuth base:** This wooden base provides a stable base for the telescope. It allows you to move the telescope in altitude (up/down) and azimuth (left/right).
- 7 10mm eyepiece:** The higher-power eyepiece that comes with the FunScope. Eyepieces are discussed in the **Magnification** section.
- 8 Rubber feet:** Three feet provide support for the FunScope and are skid free. This allows you to place the FunScope on smooth surfaces.

Figure 2 shows detail of the focuser:

- 9 Focus Wheels:** The focus wheels are used to bring objects into focus. By turning them you move the rack-and-pinion **focuser (4)** in and out.
- 10 Eyepiece securing thumbscrews:** These thumbscrews are used to keep the **eyepiece (1)** secure in the **focuser (4)**.

Items not shown:

**Primary Mirror:** The large spherical mirror inside the **optical tube (3)** gathers incoming light and focuses it with its parabolic shape.

**Secondary Mirror:** The secondary mirror is located near the opening of the **optical tube (3)** and reflects the focused light from the **primary mirror** into the **eyepiece (1)**.

## Assembly

Assembly of the FunScope is very easy. Carefully remove the protective packaging. Your FunScope arrives assembled from the factory. You just need to

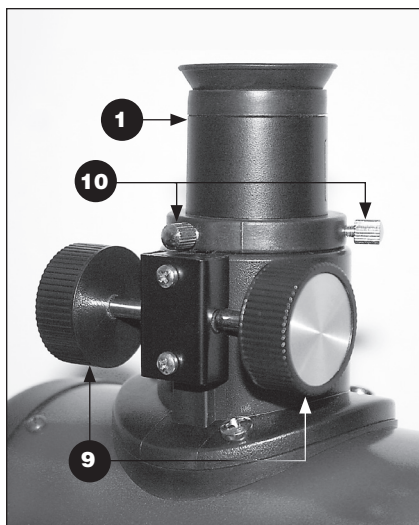

**Figure 2:** Details of the focuser

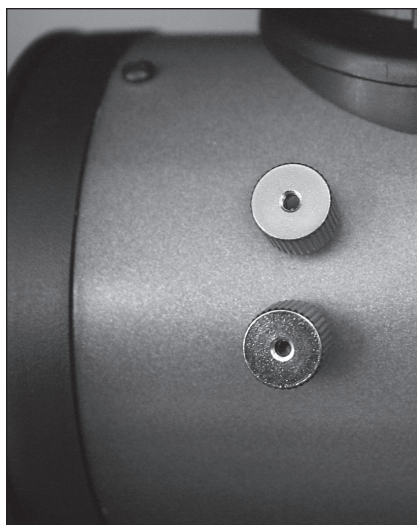

**Figure 3:** Thumbnuts for installing Red-Dot Finder bracket

install the visual accessories. These will be found in a box within the main box. Please save all original packaging. This will help protect your FunScope if you wish to transport it or in the unlikely event repair service is necessary.

## Parts List

1 Red-dot finder reflex sight (2)

1 20mm eyepiece (1)

1 10mm eyepiece (11)

When unpacking the telescope it is suggested that you save the internal packaging. In the unlikely event the product needs to be returned the shipping materials can be re-used to ensure it arrives safely at its destination.

### Attaching the Red-dot Finder

Remove the two metal thumbscrews from the optical tube (Figure 3). Place the bracket of the Red-dot finder (2) on the tube so that the holes in the bracket slide over the two threaded posts on the tube. The EZ Finder should be oriented so that it appears as in Figure 1. Thread the thumbscrews back onto the posts to secure the Red-dot finder in place.

### Inserting the Eyepiece

Loosen the eyepiece securing thumbscrews (10). Insert the chrome barrel of the 20mm eyepiece (1) into the focuser (4) and secure it with the thumbscrews.

---

Set aside the 10mm eyepiece (11) for use later.

Your telescope is now fully assembled and should resemble Figure 1. Remove the dust cap from the front of the telescope when it is in use. Replace it when you are finished observing.

## Getting Started

It's best to get a feel for the basic functions of the FunScope during the day, before observing astronomical objects at night. This way you won't have to orient yourself in the dark! Find a spot outdoors where you'll have plenty of room to move the telescope, and where you'll have a clear view of some object or vista that is at least 1/4 mile away. It is not critical that the telescope be exactly level, but it should be placed on a relatively flat surface to ensure smooth movement.

The FunScope was designed specifically for visual observation of astronomical objects in the night sky. Like all Newtonian reflector telescopes, it is not suited for daytime terrestrial usage because the image in the eyepiece is inverted (upside-down).

### Placing the FunScope

One of the great assets of the FunScope is its extremely portable size. Due to its overall short height, you will find that viewing while sitting next to the telescope is the most comfortable. If you wish to raise the telescope off the ground so that it can be used while standing or sitting in a chair, then a platform, such as a milk crate or table can be used.

## Altitude and Azimuth (Aiming the Telescope)

The FunScope altazimuth base (6) permits motion along two axes: altitude (up/down) and azimuth (left/right) (Figure 4). Moving the telescope up/down and right/left is the "natural" way people search for objects; which makes pointing the telescope intuitive and easy.

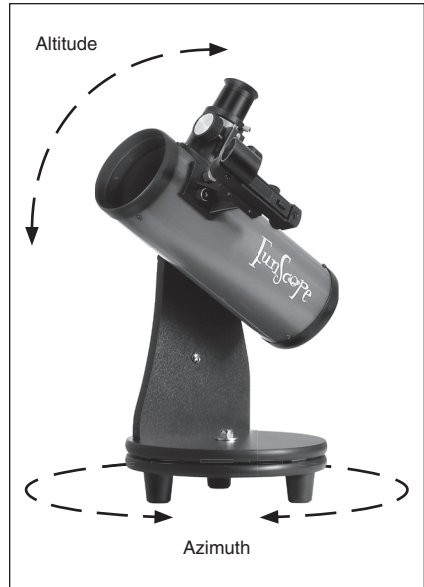

**Figure 4:** The StarBlast has two axes of motion: altitude (up/down) and azimuth (left/right).



**Figure 5:** Aiming the FunScope 76

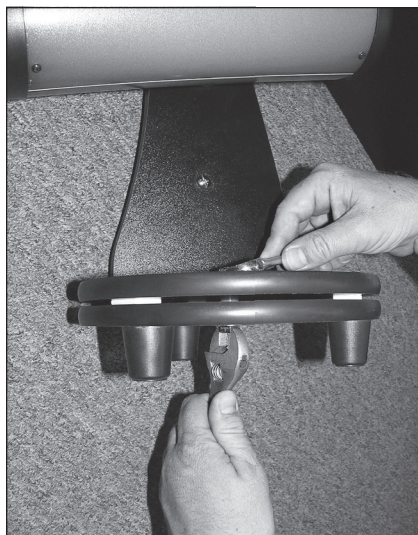

**Figure 6:** Adjusting the azimuth tension

Simply take hold of the telescope tube opening at the top or the side brace (Figure 5) and move it left or right so that the base rotates. Move it up or down in the same manner. Both motions can be made simultaneously and in a continuous manner for easy aiming. This way you can point to any position in the night sky, from horizon to horizon.

### **Tension Adjustment**

When aiming the telescope in altitude, you may find that the **optical tube(3)** is either too hard to move or does not stay in place. Use the **altitude adjustment tension knob (5)** to change the amount of tension between the **optical tube (3)** and the **altazimuth base (6)** to find the right level of tension to properly move and balance the telescope.

To adjust the azimuth tension you will need to tighten or loosen the lock nut on the circular plate at the base of the telescope. This is very easy to do; though it will require the use of two wrenches. The first is needed to hold the bolt underneath the base while the second is used to adjust the lock nut at the top of the base. (Figure 6)

### **Focusing the Telescope**

With the **20mm eyepiece (1)** inserted into the **focuser (4)** and secured with the thumbscrews, aim the **optical tube (3)** so the front (open) end is pointing in the general direction of an object at least 1/4-mile away. With your fingers, slowly rotate one of the **focus wheels (9)** until the object comes into sharp focus. Go a little bit beyond sharp focus until the image starts to blur again, then reverse the rotation of the knob, just to make sure you've hit the exact focus point.

---

## Operating the Red-dot Finder Reflex Finder

The Red-dot finder reflex finder (2) (Figure 7) works by projecting a tiny red dot onto a lens mounted in the front of the unit. When you look through the Red-dot finder, the red dot will appear to float in space, helping you locate even the faintest of deep space objects. (Figure 8) The red dot is produced by a light-emitting diode (LED), not a laser beam, near the rear of the sight. A replaceable 3-volt lithium battery provides the power for the diode.

To use the Red-dot finder, turn the power knob clockwise until you hear a “click” indicating that power has been turned on. With your eye positioned at a comfortable distance, look through the back of the reflex sight with both eyes open to see the red dot. The intensity of the dot can be adjusted by turning the power knob. For best results when stargazing, use the dimmest possible setting that allows you to see the dot without difficulty. Typically, a dim setting is used under dark skies and a bright setting is used under light-polluted skies or in daylight.

At the end of your observing session, be sure to turn the power knob counter-clockwise until it clicks off. When the two white dots on the Red-dot finder’s rail and power knob are lined up, the Red-dot finder is turned off.

### Aligning the Red-dot finder

When the Red-dot finder is properly aligned with the telescope, an object that is centered on the Red-dot finder’s red dot should also appear in the center of the field of view of the telescope’s eyepiece. Alignment of the Red-dot finder is easiest during daylight, before observing at night. Aim the telescope at a distant object at least 1/4 mile away, such as a telephone pole or chimney and center it in the telescope’s eyepiece. Now, turn the Red-dot finder on and look through it. The object should appear in the field of view near the red dot.

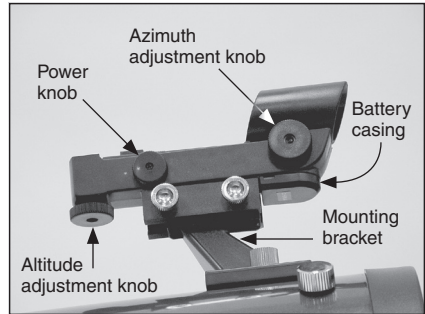

**Figure 7:** Overview of the Red-Dot Finder

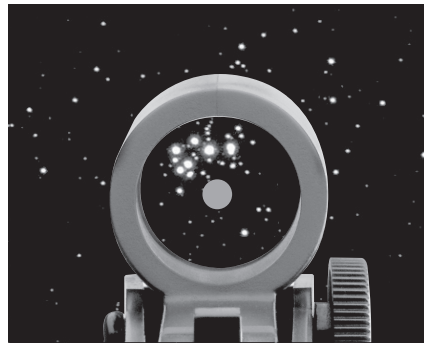

**Figure 8:** The Red-Dot finder superimposes a tiny red dot on the sky, showing right where the telescope is pointed.

---

*Note: The image in the eyepiece of the FunScope will be upside-down (rotated 180°). This is normal for Newtonian reflector telescopes.*

Without moving the telescope, use the Red-dot finder's azimuth (left/right) and altitude (up/down) adjustment knobs to position the red dot on the object in the eyepiece (Figure 7).

When the red dot is centered on the distant object, check to make sure that the object is still centered in the telescope's field of view. If not, recenter it and adjust the Red-dot finder's alignment again. When the object is centered in the eyepiece and on the red dot, the Red-dot finder is properly aligned with the telescope (Figure 8).

Once aligned, Red-dot finder will usually hold its alignment even after being removed and remounted. Otherwise, only minimal realignment will be needed.

### **Replacing the Red-dot finder Battery**

Replacement 3-volt lithium batteries for the Red-dot finder are available from many retail outlets. Remove the old battery by inserting a small flat-head screwdriver into the slot on the battery casing and gently prying open the case. Then carefully pull back on the retaining clip and remove the old battery. Do not overbend the retaining clip. Slide the new battery under the battery lead with the positive (+) side facing down and replace the battery casing.

## **Using Your Telescope**

### **Choosing an Observing Site**

When selecting a location for observing, get as far away as possible from direct artificial light such as street lights, porch lights, and automobile headlights. The glare from these lights will greatly impair your dark-adapted night vision. Avoid viewing over rooftops and chimneys, as they often have warm air currents rising from them. Similarly, avoid observing from indoors through an open (or closed) window, because the temperature difference between the indoor and outdoor air will cause image blurring and distortion.

If at all possible, escape the light-polluted city sky and head for darker country skies. You'll be amazed at how many more stars and deep-sky objects are visible in a dark sky!

### **Tracking Celestial Objects**

The Earth is constantly rotating about its polar axis, completing one full rotation every 24 hours; this is what defines a "day". We do not feel the Earth rotating, but we see it at night from the apparent movement of stars from east to west.

When you observe any astronomical object, you are watching a moving target. This means the telescope's position must be continuously adjusted over time to keep an object in the field of view. This is easy to do with the FunScope



because of its smooth motions on both axes. As the object moves off towards the edge of the field of view, just lightly nudge the telescope to re-center it.

Objects appear to move across the field of view faster at higher magnifications. This is because the field of view becomes narrower. Objects seen through the eyepiece will be upside down and reversed left-to right (rotated 180°).

### Eyepiece Selection

By using eyepieces of different focal lengths, it is possible to attain many magnifications or powers with the FunScope. Your telescope comes with two eyepieces (Figure 9): a 20mm, which gives a magnification of 30x, and a 10mm, which gives a magnification of 15x. Other eyepieces can be used to achieve higher or lower powers. It is quite common for an observer to own five or more eyepieces to access a wide range of magnifications.

To calculate the magnification of a telescope-eyepiece combination, simply divide the focal length of the telescope by the focal length of the eyepiece.

$$\frac{\text{Telescope Focal Length (mm)}}{\text{Eyepiece Focal Length (mm)}} = \text{Magnification}$$

For example, the FunScope, which has a focal length of 300mm, used in combination with the 20mm eyepiece, yields a magnification of:

$$\frac{300\text{mm}}{20\text{mm}} = 15\text{x}$$

Whatever you choose to view, always start by inserting your lowest-power (longest focal length) eyepiece to locate and center the object. Low magnification yields a wide field of view, which shows a larger area of sky in the eyepiece. This makes finding and centering an object much easier. Trying to find and center objects with a high power (narrow field of view) eyepiece is like trying to find a needle in a haystack!

Once you've centered the object in the eyepiece, you can switch to a higher magnification (shorter focal length) eyepiece, if you wish. This is recommended for small and bright objects, like planets and double stars. The Moon also takes higher magnifications well.

The best rule of thumb with eyepiece selection is to start with a low power, wide-field eyepiece, and then work your way up in magnification. If the object looks better, try an even higher magnification eyepiece. If the object looks



**Figure 9:** The 20mm and 10mm eyepieces

---

worse, then back off the magnification a little by using a lower-power eyepiece.

### **What to Expect**

So what will you see with your telescope? You should be able to see bands on Jupiter, the rings of Saturn, craters on the Moon, the waxing and waning of Venus, and many bright deep-sky objects. Do not expect to see color as you do in NASA photos, since those are taken with long-exposure cameras and have “false color” added. Our eyes are not sensitive enough to see color in deep-sky objects except in a few of the brightest ones.

Remember that you are seeing these objects using your own telescope with your own eyes! The object you see in your eyepiece is in real-time, and not some conveniently provided image from an expensive space probe. Each session with your telescope will be a learning experience. Each time you work with your telescope it will get easier to use, and stellar objects will become easier to find. Take it from us, there is big difference between looking at a well-made full-color NASA image of a deep-sky object in a lit room during the daytime, and seeing that same object in your telescope at night. One can merely be a pretty image someone gave to you. The other is an experience you will never forget!

### **Objects to Observe**

Now that you are all set up and ready to go, one critical decision must be made: what to look at?

#### **The Moon**

With its rocky surface, the Moon is one of the easiest and most interesting targets to view with your telescope. Lunar craters, maria, and even mountain ranges can all be clearly seen from a distance of 238,000 miles away! With its ever-changing phases, you’ll get a new view of the Moon every night. The best time to observe our one and only natural satellite is during a partial phase, that is, when the Moon is NOT full. During partial phases, shadows are cast on the surface, which reveal more detail, especially right along the border between the dark and light portions of the disk (called the “terminator”). A full Moon is too bright and devoid of surface shadows to yield a pleasing view. Make sure to observe the Moon when it is well above the horizon to get the sharpest images.

Use an optional Moon filter to dim the Moon when it is very bright. It simply threads onto the bottom of the eyepieces (you must first remove the eyepiece from the focuser to attach a filter). You’ll find that the Moon filter improves viewing comfort, and also helps to bring out subtle features on the lunar surface.

#### **B. The Sun**

***Never point the unfiltered FunScope at the Sun — this is not only dangerous to your eyes, but it will damage the FunScope.***

---

**Warning: Do not look at the Sun with any optical instrument without a professionally made solar filter, or permanent eye damage could result**

You can change your nighttime telescope into a daytime Sun viewer by installing an optional full-aperture solar filter over the front opening of the FunScope. The primary attraction is sunspots, which change shape, appearance, and location daily. Sunspots are directly related to magnetic activity in the Sun. Many observers like to make drawings of sunspots to monitor how the Sun is changing from day to day.

### **C. The Planets**

The planets don't stay put like the stars, so to find them you should refer to Sky Calendar at the Orion website (telescope.com), or to charts published monthly in *Astronomy*, *Sky & Telescope*, or other astronomy magazines. Venus, Jupiter, and Saturn are the brightest objects in the sky after the Sun and the Moon. Your FunScope is capable of showing you these planets in some detail. Other planets may be visible but will likely appear star-like. Because planets are quite small in apparent size, optional higher-power eyepieces are recommended and often needed for detailed observations. Not all the planets are generally visible at any one time.

**JUPITER:** The largest planet, Jupiter, is a great subject for observation. You can see the disk of the giant planet and watch the ever-changing positions of its four largest moons – Io, Callisto, Europa, and Ganymede.

**SATURN:** The ringed planet is a breathtaking sight when it is well positioned. The tilt angle of the rings varies over a period of many years; sometimes they are seen edge-on, while at other times they are broadside and look like giant "ears" on each side of Saturn's disk. A steady atmosphere (good seeing) is necessary for a good view. You will probably see a bright "star" close by, which is Saturn's brightest moon, Titan.

**VENUS:** At its brightest, Venus is the most luminous object in the sky, excluding the Sun and the Moon. It is so bright that sometimes it is visible to the naked eye during full daylight! Ironically, Venus appears as a thin crescent, not a full disk, when at its peak brightness. Because it is so close to the Sun, it never wanders too far from the morning or evening horizon. No surface markings can be seen on Venus, which is always shrouded in dense clouds.

### **D. The Stars**

Stars will appear like twinkling points of light. Even powerful telescopes cannot magnify stars to appear as more than a point of light. You can, however, enjoy the different colors of the stars and locate many pretty double and multiple stars. The gorgeous two-color double star Albireo in Cygnus is a favorite. Defocusing a star slightly can help bring out hints of color.

### **E. Deep-Sky Objects**

Under dark skies, you can observe a wealth of fascinating deep-sky objects, including gaseous nebulas, open and globular star clusters, and a variety of different types of galaxies. Most deep-sky objects are very faint, so it is impor-

---

tant that you find an observing site well away from light pollution. Take plenty of time to let your eyes adjust to the darkness. Do not expect these subjects to appear like the photographs you see in books and magazines; most will look like dim gray smudges. Our eyes are not sensitive enough to see color in deep-sky objects except in a few of the brightest ones. But as you become more experienced and your observing skills get sharper, you will be able to ferret out more and more subtle details and structure.

To find deep sky objects in the sky, it is best to consult a star chart or Planisphere. These guides will help you locate the brightest and best deep-sky objects for viewing with your FunScope.

You can also try low-power scanning of the Milky Way. Use the 20mm eyepiece and just cruise through the “star clouds” of our galaxy. You’ll be amazed at the rich fields of stars and objects you’ll see! The Milky Way is best observed on summer and winter evenings.

## Viewing Hints

Amateur astronomy can be an entertaining and educational activity for the entire family. Astronomy is also a serious scientific pursuit. As with any science you will achieve the best results by following some basic guidelines. These recommendations will assist you in getting the most out of your new telescope. This is just a sample of suggested techniques; for more helpful tips please visit the **Learning Center** at [oriontelescopes.com](http://oriontelescopes.com).

### “Seeing” and Transparency

Atmospheric conditions vary significantly from night to night. “Seeing” refers to the steadiness of the Earth’s atmosphere at a given time. In conditions of poor seeing, atmospheric turbulence causes objects viewed through the telescope to “boil”. If, when you look up at the sky with your naked eyes, the stars are twinkling noticeably, the seeing is bad and you will be limited to viewing with low powers (bad seeing affects images at high powers more severely). Planetary observing may also be poor.

In conditions of good seeing, star twinkling is minimal and images appear steady in the eyepiece. Seeing is best overhead, worst at the horizon. Also, seeing generally gets better after midnight, when much of the heat absorbed by the Earth during the day has radiated off into space.

Especially important for observing faint objects is good “transparency” – air free of moisture, smoke, and dust. All tend to scatter light, which reduces an object’s brightness. Transparency is judged by the magnitude of the faintest stars you can see with the unaided eye (6th magnitude or fainter is desirable).

If you cannot see stars of *magnitude* 3.5 or dimmer then conditions are poor. Magnitude is a measure of how bright a star is – the brighter a star is, the lower its magnitude will be. A good star to remember for this is Megrez (mag.

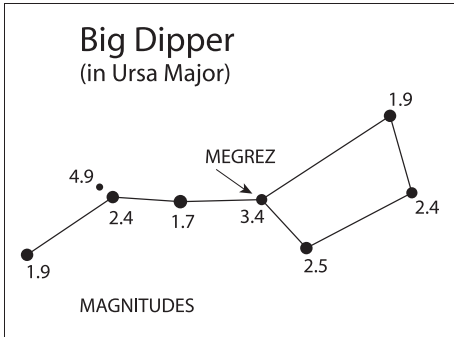

**Figure 10:** Megrez connects the Big Dipper's handle to its “pan”. It is a good guide to how conditions are. If you can not see Megrez (a 3.4 mag star) then conditions are poor.

3.4), which is the star in the “Big Dipper” connecting the handle to the “dipper”. If you cannot see Megrez, then you have fog, haze, clouds, smog, or other conditions that are hindering your viewing. (See Figure 10)

### Magnification Limits

Every telescope has a useful magnification limit of about 2X per millimeter of aperture. This comes to 152X for the FunScope. Some telescope manufacturers will use misleading claims of excess magnification, such as “See distant galaxies at 640X!”. While such magnifications are technically possible, the actual image at that magnification would be an indistinct blur.

Moderate magnifications are what give the best views. It is better to view a small, but bright and detailed image than a dim, unclear, oversized image.

### Light Pollution

Most of us live where city lights interfere with our view of the heavens. As our metropolitan areas have become more developed, the scourge of light pollution has spread, washing out many stars and nonstellar celestial objects from our sight. Faint deep sky objects become difficult or impossible to see

### Magnification Limits

Every telescope has a useful magnification limit of about 2X per millimeter of aperture. This comes to 226X for the StarBlast. Some telescope manufacturers will use misleading claims of excess magnification, such as “See distant galaxies at 640X!”. While such magnifications are technically possible, the actual image at that

magnification would be an indistinct blur.

Moderate magnifications are what give the best views. It is better to view a small, but bright and detailed image than a dim, unclear, oversized image.

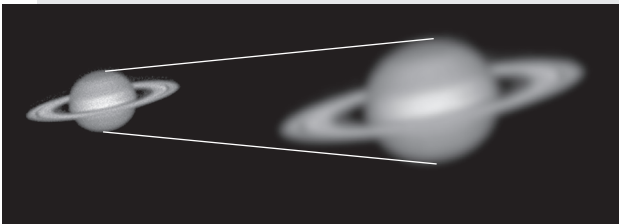

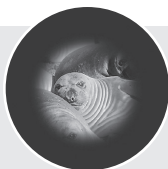

Short eye relief restricts the field of view for eyeglass wearers.



Long eye relief allows full field of view to be seen with or without eyeglasses.

## Do You Wear Eyeglasses?

If you wear eyeglasses, you may be able to keep them on while you observe. In order to do this, your eyepiece must have enough “eye relief” to allow you to see the entire field of view with glasses on. You can try looking through the eyepiece first with your glasses on and then with them off, to see if the glasses restrict the view to only a portion of the full field. If the glasses do restrict the field of view, you may be able to observe with your glasses off by just refocusing the telescope to your unaided vision.

If your eyes are astigmatic, images will probably appear best with glasses on. This is because a telescope’s focuser can accommodate for nearsightedness or farsightedness, but not astigmatism. If you have to wear your glasses while observing and cannot see the entire field of view, you may want to purchase additional eyepieces that have longer eye relief.

through the murk of light pollution. Even bright nebulae like the Orion and Lagoon Nebulae lose much of their delicate detail. The Moon and planets are not affected; they require steady air more than dark skies, so they remain good targets for city-dwelling observers.

The International Dark-Sky Association is waging the fight against light pollution. The IDSA was founded in 1988 with the mission of educating the public about the adverse impact that light pollution has on the night sky and astronomy. Through educational and scientific means, the nonprofit IDA works to raise awareness about the problem and about measures that can be taken to solve it.

Do you need help dealing with local officials to control street or building lighting in your area? The IDA’s extensive support materials can show you how. Help preserve dark skies, join the IDA today! For information, write to IDA, 3225 N. First Ave., Tuscon, AZ 85719-2103 or visit their website: [www.darksky.org](http://www.darksky.org).

The best way to avoid immediate problems with light pollution, however, is to take your telescope to where there are dark skies. You will be amazed at how many stars you can see when you get away from the city lights.

## Do You Wear Eyeglasses?

If you wear eyeglasses, you may be able to keep them on while you observe. In order to do this, your eyepiece must have enough “eye relief” to allow you to see the entire field of view with glasses on. You can try looking through the eyepiece first with your glasses on and then with them off, to see if the glasses restrict the view to only a portion of the full field. If the glasses do restrict the field of view, you may be able to observe with your glasses off by just refocusing the telescope to your unaided vision.

---

If your eyes are astigmatic, images will probably appear best with glasses on. This is because a telescope's focuser can accommodate for nearsightedness or farsightedness, but not astigmatism. If you have to wear your glasses while observing and cannot see the entire field of view, you may want to purchase additional eyepieces that have longer eye relief.

## Care and Maintenance

If you give your telescope reasonable care, it will last a lifetime. Store it in a clean, dry, dust-free place, safe from rapid temperature changes and humidity. Do not store the telescope outdoors, although storage in a garage or shed is OK. Small components like eyepiece and other accessories should be kept in a protective box or storage case. Keep the dust caps on the front of the scope and on the focuser when it is not in use.

The telescope requires very little mechanical maintenance. The optical tube is made of steel and has a smooth painted finish that is fairly scratch resistant. If a scratch does appear on the tube, it will not harm the telescope. Smudges on the tube can be wiped off with a soft cloth and a household cleaner such as Windex or Formula 409.

Refer to Appendix B for detailed instructions on how to clean the optics of the FunScope.

## Specifications

Primary mirror diameter:	76mm
Primary mirror diameter:	Spherical
Secondary mirror minor axis:	28mm
Focal length:	300mm
Focal Ratio:	f/3.9
Mirror Coatings:	Aluminum with SiO <sub>2</sub> overcoat
Focuser:	Rack-and-pinion, accepts 1.25" eyepieces
Eyepieces:	20mm and 10mm, 1.25"
Magnification:	15x (with 20mm), 30x (with 10mm)
Finder:	Red-dot finder reflex sight
Weight:	4 lbs.
Tube Length:	10.25"
Tube Outer Diameter:	3.8"

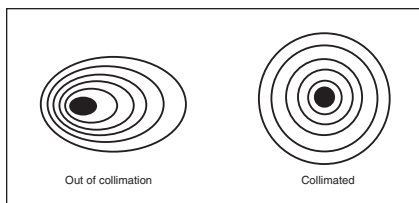

**Figure 11.** A star test will determine if the telescope's optics are properly collimated. An unfocused view of a bright star through the eyepiece should appear as illustrated on the right if optics are perfectly collimated. If the circle is unsymmetrical, as illustrated on the left, the scope needs collimation.

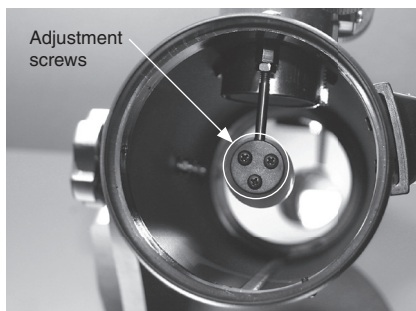

**Figure 12:** Adjust the tilt of the secondary mirror by adjusting the alignment screws with a Phillips-head screwdriver.

## Appendix A: Collimating (Aligning the Mirrors)

Collimating is the process of adjusting the mirrors so they are perfectly aligned with one another. Your telescope's optics were aligned at the factory, and should not need much adjustment unless the telescope is handled roughly. It is only recommended you make changes if the telescope is grossly out of alignment. Slight variations should still provide acceptable viewing under most conditions.

### Star-Testing the Telescope

When it is dark, point the telescope at a bright star and accurately center it in the eyepiece's field of view. Slowly de-focus the image with the focusing knob. If the telescope is correctly collimated, the expanding disk should be a perfect circle (Figure 11). If the image is unsymmetrical, the scope is out of collimation. The dark shadow cast by the secondary mirror should appear in the very center of the out-of-focus circle, like the hole in a donut. If the "hole" appears off-center, the telescope is out of collimation.

*NOTE: If you try the star test and the bright star you have selected is not accurately centered in the eyepiece, the optics will always appear out of collimation, even though they may be perfectly aligned. It is critical to keep the star centered, so over time you will need to make slight corrections to the telescope's position in order to account for the sky's apparent motion.*

### Aligning the Secondary Mirror

Only the secondary mirror can be adjusted on the FunScope. If the secondary mirror seems off center, or the star test as described above is showing an elliptical or off center diffraction pattern you may need to adjust the tilt of the mirror using the three phillips-head screws on the secondary holder (Figure 12).



---

## **Appendix B: Cleaning the Optics**

### **Cleaning Lenses**

Any quality optical lens cleaning tissue and optical lens cleaning fluid specifically designed for multi-coated optics can be used to clean the exposed lenses of your eyepieces. Never use regular glass cleaner or cleaning fluid designed for eyeglasses

Before cleaning with fluid and tissue, blow any loose particles off the lens with a blower bulb or compressed air. Then apply some cleaning fluid to a tissue, never directly on the optics. Wipe the lens gently in a circular motion, then remove any excess fluid with a fresh lens tissue. Oily fingerprints and smudges may be removed using this method. Use caution; rubbing too hard may scratch the lens. On larger lenses, clean only a small area at a time, using a fresh lens tissue on each area. Never reuse tissues.

### **Cleaning Mirrors**

You should not have to clean the telescope's mirror very often. Covering the telescope with the dust cap when it is not in use will help prevent dust from accumulating on the mirrors. However, when bringing the telescope inside after an evening's viewing it is normal for moisture to accumulate on the mirror due to the change in temperature. We suggest leaving it uncovered overnight to allow this condensation to evaporate. Improper cleaning can scratch mirror coatings, so the fewer times you have to clean the mirrors, the better. Small specks of dust or flecks of paint have virtually no effect on the visual performance.

If either mirror needs cleaning please contact Orion Technical Support at (800) 676-1343 or email us at: [support@telescope.com](mailto:support@telescope.com).





---

**WARNING:** *Never look at the sun with your telescope (or even with just your eyes) without a professionally made solar filter. Permanent eye damage or blindness could result. Young children should use this telescope only with adult supervision.*

*Avoid using the type of solar filter that screws into an eyepiece. They are susceptible to cracking under the intense heat that builds up near the focus point, and could cause severe retinal damage. Use only the type of solar filter that covers the front of the telescope. Be sure also to cover the front of the finder scope with aluminum foil or another opaque material to prevent physical damage to the internal components of the scope itself as well as to your eyes.*

Copyright © 2015 Orion Telescopes & Binoculars  
All Rights Reserved. No part of this product instruction or any of its contents may be reproduced, copied, modified or adapted, without the prior written consent of Orion Telescopes & Binoculars.

## **One-Year Limited Warranty**

The FunScope is warranted against defects in materials or workmanship for a period of one year from the date of purchase. This warranty is for the benefit of the original retail purchaser only. During this warranty period Orion Telescopes & Binoculars will repair or replace, at Orion's option, any warranted instrument that proves to be defective, provided it is returned postage paid to: Orion Warranty Repair, 89 Hangar Way, Watsonville, CA 95076. If the product is not registered, proof of purchase (such as a copy of the original invoice) is required.

This warranty does not apply if, in Orion's judgment, the instrument has been abused, mishandled, or modified, nor does it apply to normal wear and tear. This warranty gives you specific legal rights, and you may also have other rights, which vary from state to state. For further warranty service information, contact: Customer Service Department, Orion Telescopes & Binoculars, 89 Hangar Way, Watsonville, CA 95076; (800) 676-1343.

**Orion Telescopes & Binoculars**  
89 Hangar Way, Watsonville, CA 95076  
**Customer Support Help Line (800) 676-1343**